

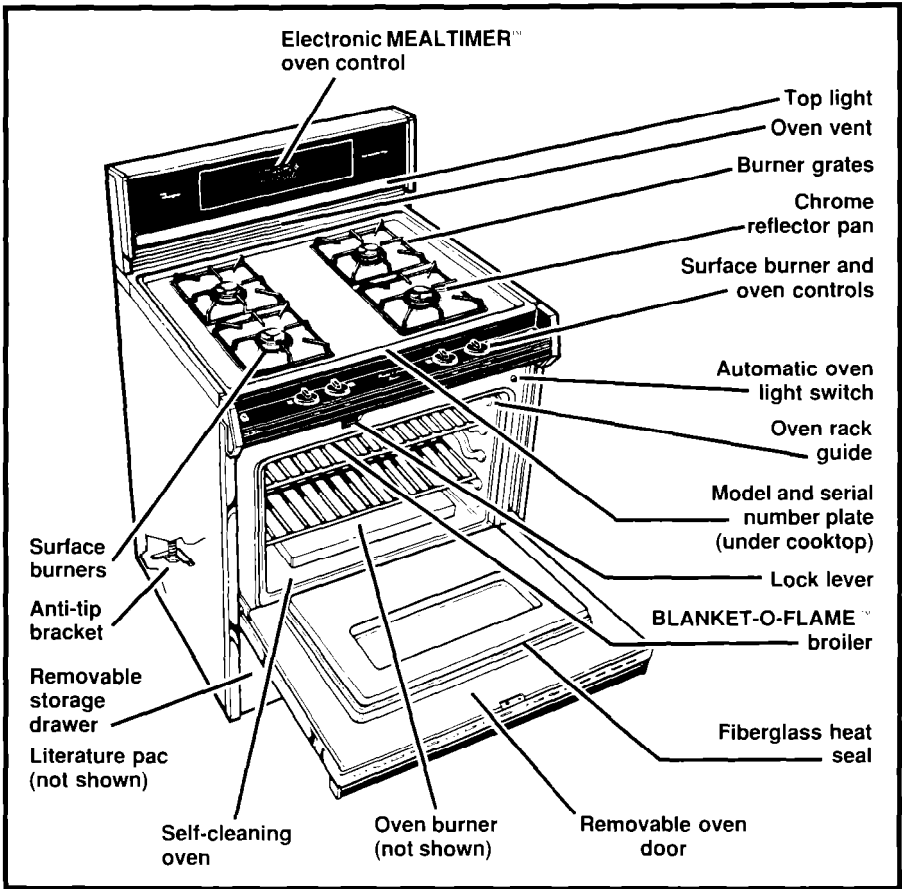

Use & Care Guide



SELF-CLEANING GAS RANGE
SF395PEW

Contents

	Page
Important Safety Instructions	3
Using Your Range	6
Using the surface burners	6
The electronic oven controls	7
Setting the clock	9
Using the electronic Minute Timer ...	9
Using the Oven Off button	10
Using the oven	10
Baking	10
Broiling	11
Using the electronic MEALTIMER™ control	12
The oven vent	16
The storage drawer	17
Caring For Your Range	18
Control panel and knobs	18
Surface burner grates and reflector pans	19
Surface burners	20
Removable cooktop	21
Using the Self-Cleaning cycle	22
Cleaning tips	27
Using and replacing the light bulbs	28
If You Need Service Or Assistance	30
Whirlpool Range Warranty	32

©1990 Whirlpool Corporation

Thank you for buying a Whirlpool appliance. Please complete and mail the Owner Registration Card provided with this product. Then complete the form below. Have this information ready if you need service or call with a question.

- Copy model and serial numbers from plate (located as shown) and purchase date from sales slip.
- Keep this book, the Cooking Guide and sales slip together in the Literature Pac.

Model Number

Serial Number

Purchase Date

Service Company Phone Number

You are responsible for:

- Installing and leveling the range on a floor strong enough to support its weight, and where it is protected from the elements. (See the Installation Instructions.)
- Making sure the range is not used by anyone unable to operate it properly.
- Properly maintaining the range.
- Using the range only for jobs expected of a home range.
- Making sure the range is secured by properly installed anti-tip bracket(s), with rear leveling leg(s) positioned under bracket(s).

Remove the Consumer Buy Guide label. It will be easier to remove before the range is used. To remove any remaining glue:

- Rub briskly with thumb to make a ball, then remove.
or
- Soak area with liquid hand dishwashing detergent before removing glue as described above.

Do not use sharp instruments, rubbing alcohol, flammable fluids or abrasive cleaners. These can damage the finish. See "Important Safety Instructions" on page 3.

Important Safety Instructions

Gas ranges have been thoroughly tested for safe and efficient operation. However, as with any appliance, there are specific installation and safety precautions which must be followed to ensure safe and satisfactory operation.

⚠ WARNING

To reduce the risk of fire, electrical shock, injury to persons, or damage when using the range, follow basic precautions, including the following:

• FOR YOUR SAFETY •

DO NOT STORE OR USE GASOLINE OR OTHER FLAMMABLE VAPORS AND LIQUIDS IN THE VICINITY OF THIS OR ANY OTHER APPLIANCE. THE FUMES CAN CREATE A FIRE HAZARD OR EXPLOSION.

• FOR YOUR SAFETY •

IF YOU SMELL GAS:

- 1. OPEN WINDOWS.**
- 2. DON'T TOUCH ELECTRICAL SWITCHES.**
- 3. EXTINGUISH ANY OPEN FLAMES.**
- 4. IMMEDIATELY CALL YOUR GAS SUPPLIER.**

IMPROPER INSTALLATION, ADJUSTMENT, ALTERATION, SERVICE OR MAINTENANCE CAN CAUSE INJURY OR PROPERTY DAMAGE. REFER TO THIS MANUAL. FOR ASSISTANCE OR ADDITIONAL INFORMATION CONSULT A QUALIFIED INSTALLER, SERVICE AGENCY, MANUFACTURER (DEALER) OR THE GAS SUPPLIER.

- IMPORTANT -

TO THE INSTALLER: PLEASE LEAVE THIS INSTRUCTION BOOK WITH THE UNIT.

TO THE CONSUMER: PLEASE READ AND KEEP THIS BOOK FOR FUTURE REFERENCE.

Important Safety Instructions Continued

- Install or locate the range only in accordance with the provided Installation Instructions. It is recommended that the range be installed by a qualified installer. The range must be properly connected to the proper gas supply and checked for leaks. The range must also be properly connected to electrical supply and grounded.



- To reduce the risk of tipping of the appliance, the appliance must be secured by properly installed anti-tip bracket(s). To check if the bracket(s) is installed properly, remove the storage drawer (see page 17) and verify that the anti-tip bracket(s) is engaged.
- Gas fuels and combustion can result in potential exposure to chemicals known to cause cancer or reproductive harm. For example, benzene is a chemical which is a part of the gas supplied to the range. It is consumed in the flame during combustion. However, exposure to a small amount of benzene is possible if a gas leak occurs. Formaldehyde, carbon monoxide and soot are by products of incomplete combustion. Properly adjusted burners with a bluish rather than a yellow flame will minimize incomplete combustion.
- Do not operate the range if it is not working properly, or if it has been damaged.
- Do not use the range for warming or heating the room. Persons could be burned or injured, or a fire could start.
- Use the range only for its intended use as described in this manual.
- Do not wear loose or hanging garments when using the range. They could ignite if they touch a hot surface burner and you could be burned.
- Do not touch surface burners, areas near burners or interior surfaces of oven. Areas near surface burners and interior surfaces of an oven become hot enough to cause burns. During use, do not touch, or let clothing or other flammable materials contact surface burners, areas near surface burners or interior surfaces of oven. Other surfaces of the range may become hot enough to cause burns; such as, the oven vent opening, the surface near the vent opening, the cooktop, the oven door and window.
- Make sure the utensils you use are large enough to contain food and avoid boil-overs and spill-overs. Heavy splattering or spill-overs left on a range can ignite and burn you. Pan size is especially important in deep fat frying.
- Turn pan handles inward, but not over other surface burners. This will help reduce the chance of burns, igniting of flammable materials, and spills due to bumping of the pan.
- Use only dry potholders. Moist or damp potholders on surface burners may result in burns from steam. Do not let potholder touch surface burners. Do not use a towel or bulky cloth for a potholder. They could catch on fire.
- Check to be sure glass cooking utensils are safe for use on the range. Only certain types of glass, glass-ceramic, ceramic, earthenware or other glazed utensils are suitable for ranges without breaking due to the sudden change in temperature.

- Do not use decorative covers or trivets over the surface burners.
- Do not heat unopened containers. They could explode. The hot contents could cause burns and container particles could cause injury.
- Grease is flammable and should be handled carefully. Let fat cool before attempting to handle it. Do not allow grease to collect around cooktop or in vents. Wipe spill-overs immediately.
- Do not use water on grease fires. Never pick up a flaming pan. Smother flaming pan on range by covering with a well-fitted lid, cookie sheet or flat tray. Flaming grease outside of pan can be extinguished with baking soda or, if available, a multipurpose dry chemical or foam-type extinguisher.
- Never leave surface burners unattended at high heat settings. A boil-over could result and cause smoking and greasy spill-overs that may ignite.
- Make sure surface burners are off when you are finished, and when you aren't watching.
- Use care when opening oven door. Let hot air or steam escape before removing or replacing food.
- Always position oven racks in desired location while oven is cool.
- Do not store flammable materials on or near the range. They could explode or burn.
- Do not store things children might want above the range. Children could be burned or injured while climbing on it.
- Do not leave children alone or unattended in area where the range is in use. They should never be allowed to sit or stand on any part of the range. They could be burned or injured.
- Never use a match or other flame to look for a gas leak. Explosion and injury could result.
- Know where your main gas shut off valve is located.
- Keep range vents unobstructed.
- Clean your range regularly. See care and cleaning instructions in this manual.
- Be sure all range parts are cool before cleaning.
- Do not clean door heat seal. It is essential for a good seal. Care should be taken not to rub, damage, or move the seal. Clean only parts recommended in this Use and Care Guide.
- Do not use oven cleaners. No commercial oven cleaner or oven liner protective coating of any kind should be used in or around any part of the oven.
- Before self-cleaning the oven, remove broiler pan, broiler grid, oven racks and other utensils. Do not use your oven to clean miscellaneous parts.
- Do not repair or replace any part of the range unless specifically recommended in this manual. All other servicing should be referred to a qualified technician.
- Disconnect the electrical supply before servicing the range.

- SAVE THESE INSTRUCTIONS -

Using Your Range

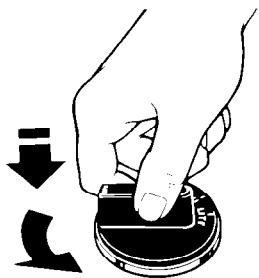

Surface burner marker 

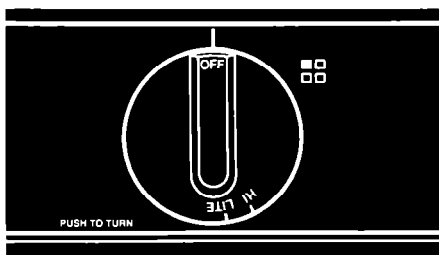

Using the surface burners

Control knobs must be pushed in, then turned to the LITE position. The clicking sound is the ignition sparking.

To stop the clicking sound after the burner lights, turn the control knob back to a desired setting. The control knob has stops for HI, MED and LOW, however, it can be set anywhere between HI and OFF.

Surface burner markers

The solid dot in the surface burner marker shows which surface burner is turned on by that knob.

Until you get used to the settings, use the following as a guide. For best results, start cooking at the high settings; then turn the control knob down to continue cooking.

Use LITE to light the burner. After the burner lights, turn control back to a desired setting to stop the clicking of the ignition.

Use HI to start foods cooking; to bring liquids to a boil.

Use a medium setting to continue cooking or to fry chicken or pancakes; for gravy, puddings and icing; to cook large amounts of vegetables.

Use a low setting to keep food warm until ready to serve.

NOTE: Do not cook with the control in the LITE position.

In case of a prolonged power failure:

Surface burners can be manually lighted. Hold a lighted match near a burner and turn the control to the LITE position. After the burner lights, turn the control to the desired setting.

⚠ WARNING**Burn, Fire and Explosion Hazard**

- **Burner flame should not extend beyond the edge of the cooking utensil. The flame can burn you and cause poor cooking results.**
- **Be sure all control knobs are turned to OFF when you are not cooking. Someone could be burned or a fire could start if a burner is accidentally left ON.**
- **If the flame should go out while cooking, or if there is a strong gas odor, turn the burners OFF. Wait five minutes for the gas odor to disappear, before relighting burner. If gas odor is still present, see safety note on page 3. Failure to follow these precautions could result in explosion or fire.**
- **Do not attempt to light the oven burner during a power failure. Personal injury could result.**

The electronic oven controls

There are three parts in the oven control section:

- The digital display.
- The command buttons.
- The Set Knob.

Instructions for each oven control are covered on the following pages. Read them carefully.

When you first plug in the range, the time display will flash until you set a new time. If, after you set the clock (page 9) the time display flashes, your electricity was off for a while. Reset the clock.



Using Your Range Continued



Digital display/clock

When you are not using the oven, this is an accurate digital clock. When using the oven or Minute Timer, the display will show the time, temperature settings and what command buttons have been pressed.

When showing the time of day, the display will show the hour and minutes.

When using the Minute Timer, the display shows minutes and seconds in the following sequence:

- For settings from 0 minutes to 1 minute 55 seconds, the display will increase in 5-second increments.
- For settings from 2 minutes to 9 minutes 50 seconds, the display will increase in 10-second increments.
- For settings from 10-59 minutes, the display will increase in 1 minute increments.
- For settings from 1 hour to 1 hour 55 minutes, the display will increase in 5-minute increments.
- For settings from 2 hours to 9 hours 50 minutes, the display will increase in 10-minute increments.

When using Bake Time, the display shows hours and minutes.

Command buttons

The command buttons tell the oven what to do and in what order. A few examples:

- Clock tells the oven you are going to set the clock.
- Oven Off tells the oven to turn off.

Each command button (except Oven Off) has its own indicator. The indicator comes on when you touch the command buttons.

Set Knob

Once you've pushed a command button to tell the oven what you want it to do, you'll use the Set Knob to set a temperature or time. Turning the Set Knob clockwise increases the number on the display. Turning the Set Knob counterclockwise decreases the number on the display.

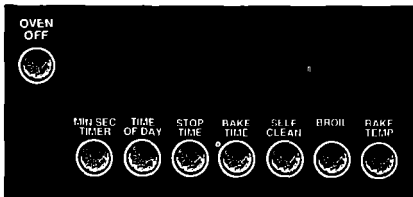

TIME
OF DAY



SET
KNOB



TIME

1:00

OVEN
OFF



Setting the clock

1. Push the Time of Day button. The TIME indicator will show in the display. Release the Time of Day button.
2. Turn the Set Knob until the correct time shows in the large display.
3. Push the Oven Off button to complete time of day entry.

MIN/SEC
TIMER



TIMER

0:00

SET
KNOB



Using the electronic Minute Timer

The Minute Timer does not start or stop the oven. It works like a kitchen timer. It can be set in minutes and seconds up to 9 hours, 50 minutes. You will hear three beeps when the set time is up.

1. Push the Min/Sec Timer button. The TIMER indicator will come on and the large display will show "0:00".
2. Turn the Set Knob until the desired time shows in the large display. The Minute Timer will begin counting down 2 seconds after the time is set.
When time is up, you will hear three beeps.

**BEEP
BEEP
BEEP**

Using Your Range Continued

To cancel the Minute Timer:

- Push the Min/Sec Timer button and turn the Set Knob until "0:00" shows in the large display.

Using the Oven Off button

The Oven Off button will cancel any command except for times set with the Min/Sec Minute Timer button. The large display will then show the time of day or, if Minute Timer is also being used, the time remaining.



Using the oven

Baking

1. Position the racks properly **before** turning on the oven. **To change rack position**, pull rack out to stop, raise front edge and lift out.

The rack(s) should be placed so the top of the food will be centered in the oven. Always leave at least 1 1/2 to 2 inches (4-5 cm) between the sides of the pan and the oven walls and other pans. For more information, see the Cooking Guide.

2. Push the Bake Temp button. "---°F" will show in the small display.

NOTE: If the oven door is latched when you try to bake, "door" will appear in the large display and you will be unable to continue. If the LOCK indicator is on, wait until it goes off. Then move the Lock Lever **all the way** to the left to unlatch the door.

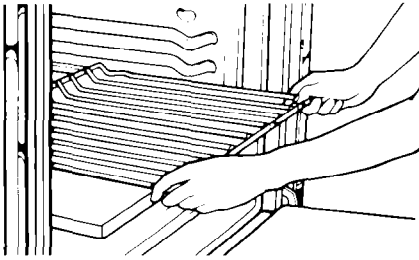

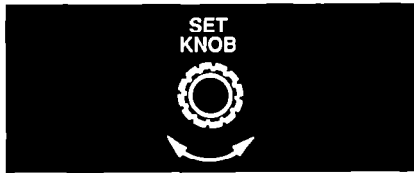

3. To set a baking temperature, turn the Set Knob until the desired temperature shows in the small display. The display will increase in 5°F increments. The BAKE and ON indicators will come on. The burner will light in 50-60 seconds.

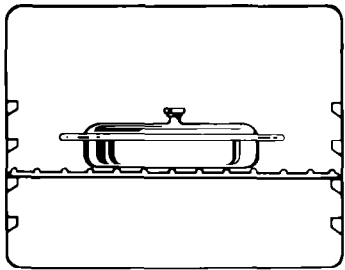

4. Put food in the oven.
During baking, the oven burner will turn on and off to keep the oven temperature at the setting.



5. When baking is done, push the Oven Off button or turn the Set Knob until "---F" shows in the small display. The oven will then shut off.

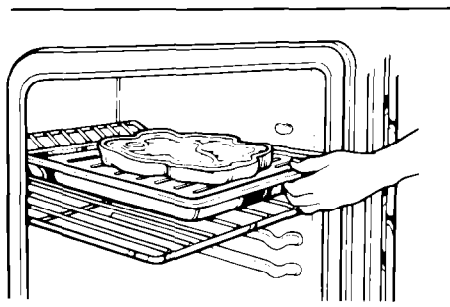

Broiling

The BLANKET-O-FLAME™ Broiler uses *infra-red* rays to cook the food. *Infra-red* rays create fast, searing heat and consume most smoke and spatters.

Always broil with the oven door closed.

1. Position the rack **before** turning the oven on. See rack placement chart and broiling chart in the "Cooking Guide" for recommended rack positions and broiling times.
2. Put the broiler pan and food on the rack and completely close the oven door.

Using Your Range Continued



3. Push the Broil button. "--" will show in the small display and the BROIL indicator will come on.

NOTE: If the oven door is latched when you try to broil, "door" will appear in the large display and you will be unable to continue. If the LOCK indicator is on, wait until it goes off. Then move the Lock Lever **all the way** to the left to unlatch the door.

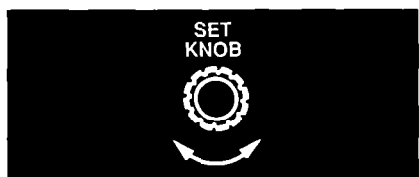

4. You can broil at one of two temperatures. To cook at the lower temperature, turn the Set Knob one click and "lo" will appear in the small display. To cook at the higher temperature, turn the Set Knob two clicks and "hi" will appear in the small display. When the oven turns on, the ON indicator will come on. The burner lights automatically in 50-60 seconds.



5. When broiling is done, push the Oven Off button. The time of day will then show in the large display.

Using the electronic MEALTIMER™ control

The electronic MEALTIMER control will turn the oven on and off at times you set...even when you are not around.

Automatic baking is ideal for foods which do not require a preheated oven, such as meats and casseroles. **Do not use the automatic cycle for cakes, cookies, etc...undercooking will result.**

To start baking now and stop automatically:

1. Position the oven racks properly and place the food in the oven.
2. Push the Bake Time button. “:00” will show in the large display.



3. Turn the Set Knob clockwise until the desired baking time, up to 11 hours 55 minutes, shows in the large display.



4. Push the Bake Temp button and set the desired temperature. The display will show the set temperature and the time remaining. The OVEN, TIME, BAKE and ON indicators will come on.
5. The display will count down in 5 and 10-minute increments.
6. When baking time is completed, the oven will turn off automatically, beep 3 times, and the time of day will show in the large display.



BEEP BEEP BEEP

Using Your Range Continued



To delay start and stop automatically:

1. Position the oven racks properly and place the food in the oven.
2. Push the Bake Time button. ":00" will show in the large display.



3. Turn the Set Knob clockwise until the desired baking time shows in the display.

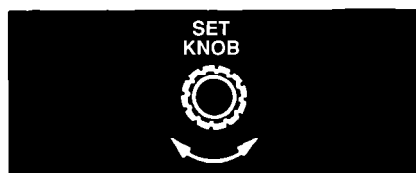
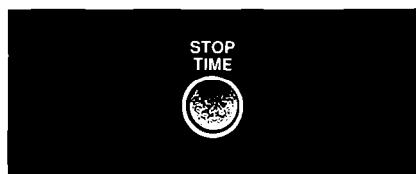

4. Push the Stop Time button. The DELAY, OVEN, STOP and TIME indicators will come on. Turn the Set Knob clockwise until the desired stop time shows in the large display.

The oven will beep once every 10 seconds until a baking temperature is selected.



5. Push the Bake Temp button and set the desired temperature. The BAKE indicator will come on.
6. Changes can be made at any time by pressing a command button.



7. When the start time is reached, the DELAY and OVEN indicators will go off. The display will show the set temperature and the ON indicator will come on.

BEEP BEEP BEEP

8. When the baking time is completed, the oven will turn off automatically, beep 3 times, and the time of day will show in the large display.



To cancel the MEALTIMER™ control setting:

- Push the Oven Off button or turn the Set Knob until ":00" appears in the large display. The time of day will then show in the large display.

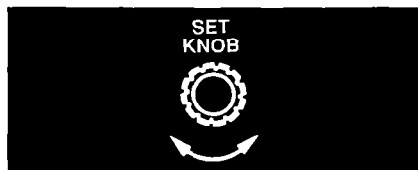

⚠ WARNING

To avoid sickness and food waste when using the MEAL-TIMER™ control:

- Do not use foods that will spoil while waiting for cooking to start, such as dishes with milk or eggs, cream soups, and cooked meats or fish. Any food that has to wait for cooking to start should be very cold or frozen before it is put in the oven. **MOST UNFROZEN FOODS SHOULD NEVER STAND MORE THAN TWO HOURS BEFORE COOKING STARTS.**
- Do not use foods containing baking powder or yeast when using delay start. They will not rise properly.
- Do not allow food to remain in oven for more than two hours after end of cooking cycle.

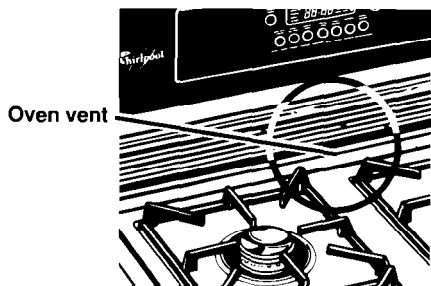

The oven vent

Hot air and moisture escape from the oven through a vent just under the cooktop light. The vent is needed for air circulation. **Do not block the vent.** Poor baking will result.

⚠ WARNING

Burn Hazard

When the oven is ON, pans and pan handles left near the oven vent can become hot enough to burn the user and to melt plastics. Use potholders to move pans. Never store plastics, paper or other items that could melt or burn near the oven vent, or any of the surface burners.

The storage drawer

The storage drawer is for storing pots and pans. The drawer can be removed to make it easier to clean under the range, and to check for installation of the anti-tip bracket(s). **Use care when handling the drawer.**

Removing the storage drawer:

1. Empty drawer of any pots and pans before removing drawer. Pull drawer straight out to the stop.
2. Push up black plastic lever on both sides of drawer.
3. Pull drawer out a little farther until levers stay in "up" position. Pull drawer the rest of the way out.

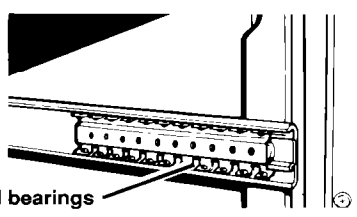
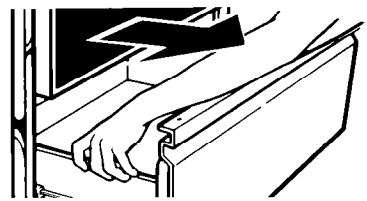
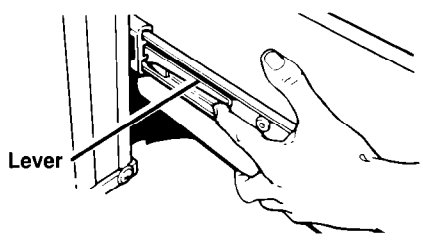

Replacing the storage drawer:

1. Make sure ball bearings on oven slide rail are positioned toward the front of the opening.
2. Fit ends of drawer slide rails into the oven slide rails on both sides of opening.
3. Slide drawer closed.

Use and care guide storage

Store this booklet, along with your Cooking Guide and sales slip in the Literature Pac, inside the storage drawer.

To verify that the anti-tip bracket(s) is engaged:

- Remove storage drawer.
- Look to see if the anti-tip bracket(s) is attached to floor with screws.
- Make sure rear leveling leg(s) is positioned under bracket(s).
- See "Important Safety Instructions" on page 4 and Installation Instructions for further details.

NOTE: The range will not tip during normal use. Tipping can occur if excessive force or weight is applied to open door without anti-tip bracket(s) properly secured.

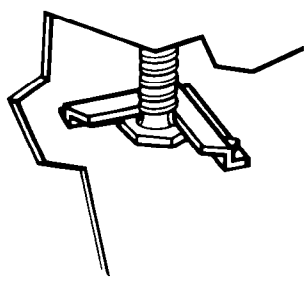

Caring For Your Range

⚠ WARNING

Burn, Electrical Shock, Fire and Explosion Hazard

- **Make sure all controls are OFF and the range is cool before cleaning.**
- **Do not use oven cleaners, bleach or rust removers.**
- **Do not use gasoline or other flammable liquids or vapors to clean this or any other appliance.**
- **Keep the appliance area clear and free from combustible materials, gasoline and other flammable vapors and liquids.**
- **Do not obstruct the flow of combustion and ventilation air.**

Failure to follow these guidelines could result in burns, electrical shock, fire or explosion.

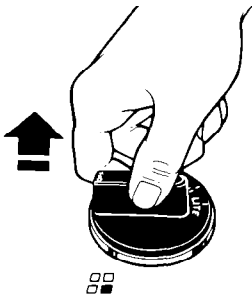

Control panel and knobs

1. Turn control knobs to the OFF position.
2. Pull control knobs and command buttons straight off.
3. Use warm soapy water or spray glass cleaner and a soft cloth to wipe the control panels. Rinse and wipe dry with a soft cloth.

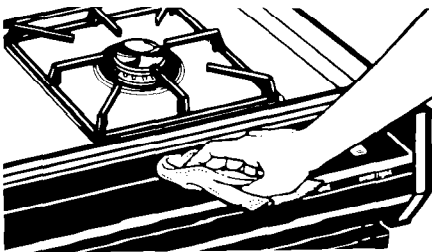

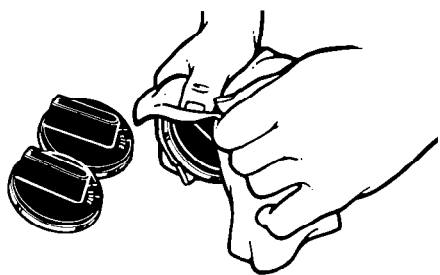

4. Wash control knobs and command buttons in warm soapy water. Rinse well and dry with a soft cloth. Do not soak.

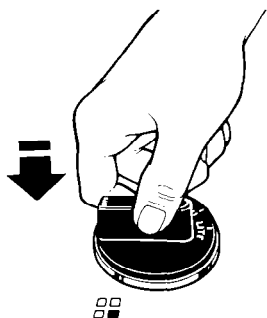

5. Replace control knobs and command buttons by pushing them firmly into place.

NOTE: When cleaning, never use steel wool, abrasives, or commercial oven cleaners which may damage the finish. After cleaning, make sure all control knobs point to the OFF position. Make sure buttons have not turned oven ON. If oven has been turned on, push Oven Off button.

Surface burner grates and reflector pans

1. Make sure all surface burners are off and the surrounding parts are cool.

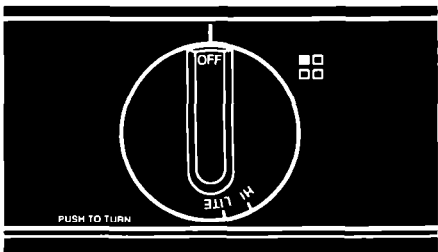

2. Lift off the burner grates and remove reflector pans.

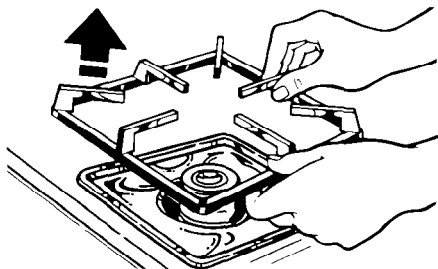

Caring For Your Range Continued

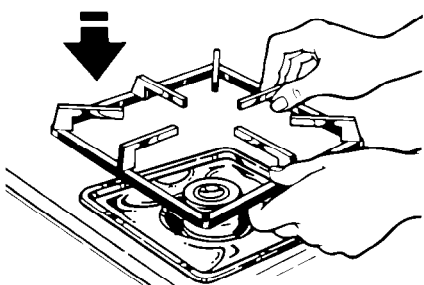
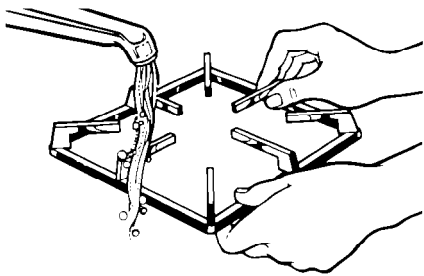

3. Wash the grates and reflector pans with warm soapy water or in a dishwasher. Use a non-abrasive plastic scouring pad for heavily-soiled areas. Rinse and dry well.

4. Replace reflector pans and burner grates.

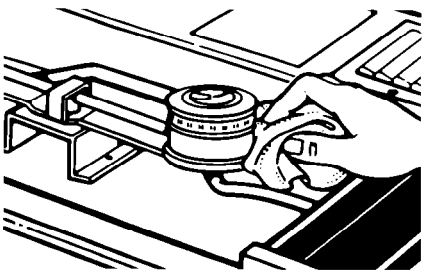

Surface burners

To remove the cooktop, follow the instructions in "Removable cooktop" on page 21.

Wipe off surface burners with warm soapy water and a soft cloth after each use.

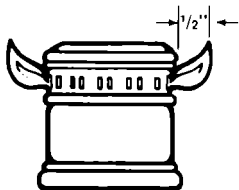

Typical surface burner flame

Occasionally check the burner flames for proper size and shape as shown. If flames lift off ports, are yellow, or are noisy when turned off, you may need to clean the burners (see "Cleaning tips" on page 27), or call a qualified technician for adjustment.

Replace cooktop.

Removable cooktop

1. Remove surface burner grates and reflector pans.

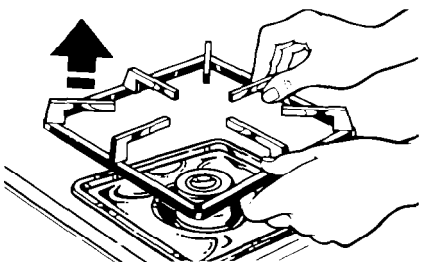

2. Lift front of cooktop enough to clear front of range. Grasp both sides of the cooktop, lift and pull forward to remove.

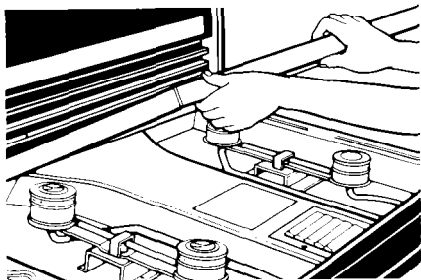

3. Wipe surface under the cooktop with warm soapy water. Use a soap-filled plastic scrubbing pad on heavily-soiled areas.
4. Replace cooktop by fitting back of cooktop into grooves in rear brackets. Lower cooktop. Replace reflector pans and surface burner grates.

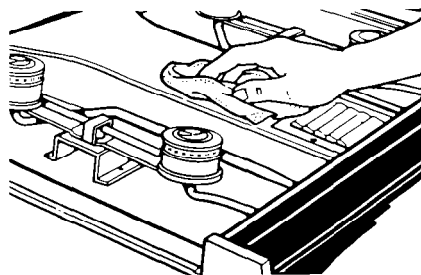

⚠ WARNING

Personal Injury and Product Damage Hazard

- Do not try to clean under the cooktop without removing it first. The cooktop could accidentally fall and injure you.
- Do not drop the cooktop. Damage can result to the porcelain and the cooktop frame.

Using the Self-Cleaning cycle

The Self-Cleaning cycle uses **very high heat** to burn away soil. Before you start, make sure you understand exactly how to use the Self-Cleaning cycle safely.

Before you start

1. Clean the areas shown by hand.

They do not get hot enough during the Self-Cleaning cycle for soil to burn away. Use hot water and detergent or a soapy steel wool pad on...

- The inside of the door. (The center area of the door does not need to be hand cleaned.)
- The frame around the oven.

Do not clean, move or bend the fiberglass seal. Poor cleaning and poor baking will result.

2. Remove the broiler pan and any pots and pans you may have stored in the oven.

NOTE: The broiler pan (without grid) can be cleaned in the oven only if most of the soil has been removed by hand-cleaning or a dishwasher. The chrome broiler grid will discolor if cleaned in the Self-Cleaning cycle.

3. Wipe out any loose soil or grease.

This will help reduce smoke during the Self-Cleaning cycle.

4. If you want the oven racks to remain shiny, remove from the oven and clean them by hand.

Otherwise, put oven racks on second and fourth guides (guides are counted from bottom to top). After racks are cleaned in the Self-Cleaning cycle, they become harder to slide. See page 27.

Turn on a vent hood or other kitchen vent during the Self-Cleaning cycle. This will help remove heat and odors that are normal during the cycle.

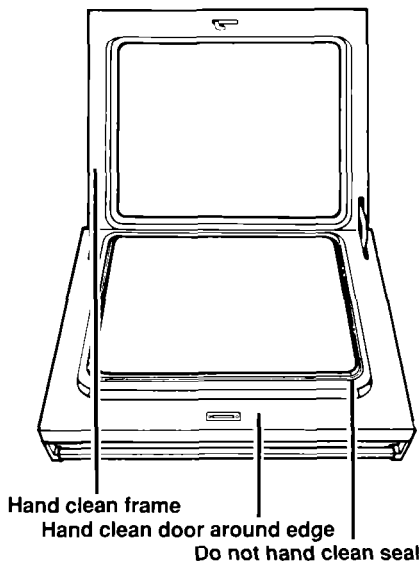

⚠ WARNING**Personal Injury and Product Damage Hazard**

- Do not touch the oven during the Self-Cleaning cycle. It could burn you.
- Do not use commercial oven cleaners in your oven. Cleaners may produce hazardous fumes or damage the porcelain finish.
- Do not force the Lock Lever, you could bend or break it. The lever is designed to stay locked until the oven is cool enough to safely open. Wait until it moves freely.
- Do not use foil or other liners in the oven. During the Self-Cleaning cycle foil can burn or melt and damage the oven surface.
- Do not block the vent during the Self-Cleaning cycle. Air must move freely for best cleaning results.
- Do not leave plastic utensils near the vent. They may melt.

Setting the controls

1. Make sure the Clock is set to the right time of day. (See "Setting the clock" on page 9.)
2. Move the Lock Lever **all the way** to the right - the Clean position.

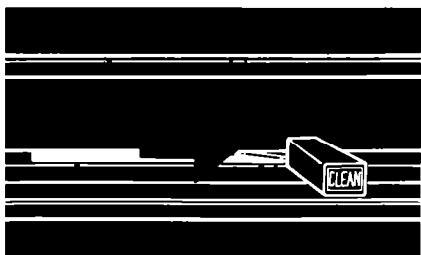

Caring For Your Range Continued



3. Push the Self Clean button. A 3-hour Self-Cleaning cycle will be set automatically. "3:00" will show in the large display. The CLEAN and TIME indicators on the left side of the display and the CLEAN and ON indicators on the right side of the display will come on.

NOTE: If the Self Clean button is pushed when the door is not latched, "door" will appear in the large display. Move the Lock Lever **all the way** to the right to latch the door. If any other command button is pushed when the door is latched, "door" will appear in the large display and you will be unable to continue. Move the Lock Lever back to the left to unlatch the door after the LOCK indicator goes off.



4. **(Option) Delayed clean:** Push the Self Clean button. Immediately push the Stop Time button. Immediately turn the Set Knob to the new stop time. The TIME, CLEAN, DELAY and STOP indicators will come on.

5. After the Self-Cleaning cycle is started, the LOCK indicator will come on when the oven temperature exceeds normal baking temperatures. The Lock Lever must not be moved and the door cannot be opened when this indicator is on.

6. **After the Self-Cleaning cycle is completed**, the CLEAN indicator will go off and the time of day will show in the large display.

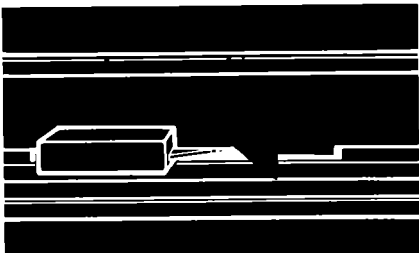

7. When the oven reaches normal baking temperatures, the LOCK indicator goes off. Move the Lock Lever back to the left. **Do not force it.** Wait until it moves easily.
8. **After the oven is cool**, wipe off any residue or ash with a damp cloth. If needed, touch up spots with a soapy steel wool pad.

Special tips

- Keep the kitchen well-ventilated during the Self-Cleaning cycle to help get rid of heat, odors and smoke.
- Clean the oven before it gets heavily soiled. Cleaning a very soiled oven takes longer and results in more smoke than usual.
- If the Self-Cleaning cycle doesn't get the oven as clean as you expected, the cycle may not have been set long enough or you may not have prepared the oven properly. Set the Self-Cleaning cycle longer the next time and hand clean areas noted on page 22.

To stop the Self-Cleaning cycle at any time:

1. Push the Oven Off button.
2. When the LOCK indicator goes off, move the Lock Lever back to the left. **Do not force it.** Wait until it moves easily.

OVEN
OFF



Caring For Your Range Continued

How it works

During the Self-Cleaning cycle, the oven gets much hotter than it does for baking or broiling...approximately 875°F (468°C). This heat breaks up grease and soil and burns it off.

This graph shows approximate temperatures and times during a Self-Cleaning cycle for three hours.

Self-Cleaning cycle - three hour setting

(Approximate temperatures and times)

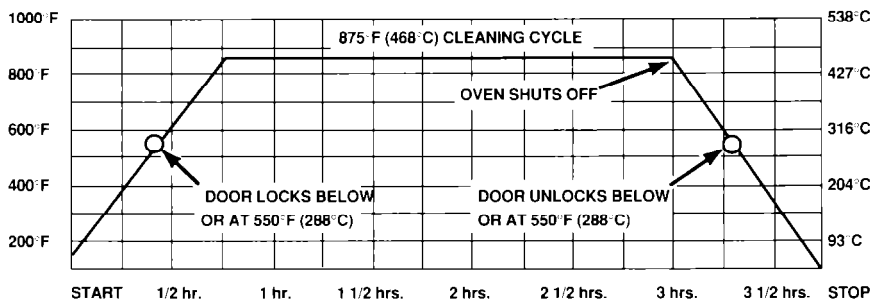

Notice that the heating stops when the 3 hour setting is up, but that it takes longer for the oven to cool down enough to unlock.

Cleaning tips

Control knobs

Clean with warm soapy water and a soft cloth.

- Wash, rinse and dry well.
- Do not soak.

Control panels

Clean with warm soapy water or spray glass cleaner and a soft cloth.

- Wash, rinse and dry well.
- Follow directions provided with the cleaner.

Exterior surfaces (other than cooktop)

Clean with warm soapy water and a soft cloth.

- Wipe off regularly when cooktop and oven are cool.

Use a non-abrasive plastic scrubbing pad for heavily-soiled areas.

- Do not use abrasive or harsh cleaners.

NOTE: Do not allow food containing acids (such as vinegar, tomato, lemon juice or milk) to remain on surface. Acids may remove the glossy finish. Be careful when cleaning around model and serial number plate; the numbers wipe off easily.

Surface burners

Clean with warm soapy water and a soft cloth.

- Remove cooktop (see page 21).
- Wipe off spills immediately after burner has cooled.

For cooked-on food:

- Remove burner from manifold with phillips screwdriver.
- Wash with warm soapy water and a non-abrasive plastic scrubbing pad.
- Rinse and dry well.
- If ports are clogged, clean with a straight pin. **Do not enlarge or distort port. Do not use a wooden toothpick.**
- Do not clean surface burner in dishwasher.

Surface burner grates and chrome reflector pans

Clean with warm soapy water and a non-abrasive plastic scrubbing pad.

- Wash, rinse and dry well.
- Dry completely.
- **Do not place in Self-Cleaning Oven.**

OR

Clean in a dishwasher.

Broiler pan and grid

Clean with warm soapy water or a soapy steel wool pad.

- Clean after each use.
- Wash, rinse and dry well.
- Do not clean in Self-Cleaning Oven. (See note on page 22.)

Oven racks

Use Self-Cleaning cycle.

- Leave in oven during Self-Cleaning cycle. **OR**

Clean with warm soapy water or soapy steel wool pads.

- Wash, rinse and dry. Use soapy steel wool pads for heavily-soiled areas.

NOTE: The oven racks will discolor and be harder to slide when left in the oven during the Self-Cleaning cycle. If you want them to stay shiny, remove from the oven and clean by hand. If racks are left in the oven during the Self-Cleaning cycle, apply a small amount of vegetable oil to the sides of the racks to make them easier to slide.

Oven door glass

Use spray glass cleaner or warm soapy water and a non-abrasive plastic scrubbing pad.

- Make sure oven is cool.
- Follow directions provided with the cleaner.
- Wash, rinse and dry well.

Self-Cleaning oven

For areas outside the Self-Cleaning area use warm soapy water or soapy steel wool pads.

- Follow directions starting on page 22, "Using the Self-Cleaning cycle."
- Do not use commercial oven cleaners.
- Do not use foil to line the bottom of your Self-Cleaning Oven.

Using and replacing the light bulbs

The cooktop light

The fluorescent light is on the bottom of the control panel. The Top Light Switch is located on the left side of the front control panel.

⚠ WARNING

Electrical Shock and Burn Hazard
Make sure power to the range has been disconnected at the main power supply and that all surface burners are OFF and cool. Failure to do so could result in electrical shock or burns.

To replace the cooktop light:

1. Turn off all control knobs and unplug appliance or disconnect at the main power supply.
 2. Pull Set Knob and all command buttons straight off.
 3. Remove the four screws in the center of the oven vent grille. **Do not remove two top screws.**
 4. **With both hands**, carefully remove oven vent grille and control panel glass.
 5. Roll bottom of fluorescent tube towards you until both ends can be pulled out of the receptacles. Replace with a 20-watt cool-white fluorescent tube.
 6. Insert control panel glass into top slot of the oven vent grille. Carefully replace glass and grille.
- NOTE:** The control panel glass must fit under the top lip of the upper control panel frame.
7. Replace the four screws in the oven vent grille.
 8. Push Set Knob and command buttons straight on.
 9. Plug in appliance or reconnect at the main power supply.

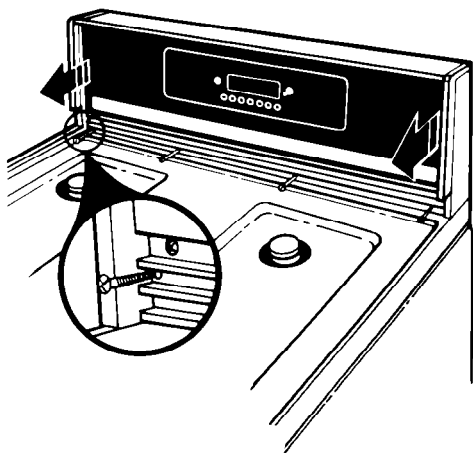

The oven light

The Oven Light will come on when you open the oven door. To turn the light on when the oven door is closed, push the Oven Light Switch on the control panel. Push the switch again to turn off the light.

⚠ WARNING

Electrical Shock and Personal Injury Hazard

- **Make sure oven and light bulb are cool and power to the oven has been turned off before replacing the light bulb. Failure to do so could result in electrical shock or burns.**
- **The bulb cover must be in place when using the oven. The cover protects the bulb from breaking, and from high oven temperatures. Since bulb cover is made of glass, be careful not to drop it. Broken glass could cause injury.**

To replace the oven light:

1. Unplug appliance or disconnect at the main power supply.
2. Remove the glass bulb cover in the back of the oven by screwing it out counterclockwise.
3. Remove the light bulb from its socket. Replace with a 40-watt appliance bulb.
4. Replace the bulb cover by screwing it in clockwise. Plug in appliance or reconnect at the main power supply.

NOTE: Make sure oven light is off during the Self-Cleaning cycle. Keeping oven light on will shorten bulb life.

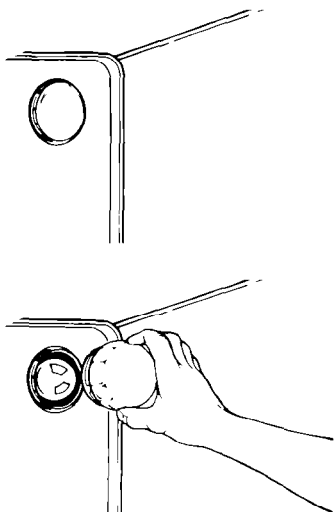

If You Need Service Or Assistance...

We suggest you follow these steps:

1. Before calling for assistance...

Performance problems often result from little things you can find and fix without tools of any kind.

If nothing operates:

- Is the gas turned on?
- Is the power supply cord plugged into a live circuit with the proper voltage? (See Installation Instructions.)
- Have you checked your home's main fuses or circuit breaker box?
- Have instructions in this book been followed?
- Is the control knob set in the correct position?
- Is the flow of combustion and/or ventilation air to the unit obstructed?

Do not obstruct air flow to and around unit.

- Recheck suspected defect.

If the oven will not operate:

- Are the electronic controls set correctly? See pages 7-16.
- Have you programmed a delay start time?

If burner fails to light:

- Is the range connected to electrical power?
- Have you checked your home's main fuses or circuit breaker box?
- Are burner ports clogged? See page 27.

If burner flames are uneven:

- Are burner ports clogged? See page 27.

If burner flames lift off ports, are yellow, or are noisy when turned off:

- The air/gas mixture may be incorrect. (Call for service.)

If burner makes a popping noise when ON:

- Is the burner wet from washing? Let dry.

If control knob(s) will not turn:

- Did you push in before trying to turn?

If the Self-Cleaning cycle will not operate:

- Does the clock show the right time of day?
- Is the Lock Lever all the way to the right?
- Have you set a delay start time?

If cooking results aren't what you expected:

- Is the range level?
- If needed, have you preheated the oven as the recipe calls for?
- Does the flame size fit the cooking utensil being used? (See the Cooking Guide.)
- If broiling, have you completely closed the oven door? BLANKET-O-FLAME™ Broiler provides best cooking results with the oven door closed.
- Are you following a tested recipe from a reliable source?
- Are you using pans recommended in the Cooking Guide?
- If baking, have you allowed 1 1/2 to 2 inches (4-5 cm) on all sides of the pans for air circulation?
- Are the pans the size called for in the recipe?
- Do the cooking utensils have smooth, flat bottoms and fit the surface burners being used?

If the oven temperature seems too low or too high:

- Was your old oven accurate? Your old oven may have shifted gradually while your new oven may be more exact.
- If, after using the oven, you are not satisfied with the temperature settings, they can be adjusted by an authorized WhirlpoolSM service technician. (See "If you need service" on page 31.)

If there has been a power interruption, the display will flash. Reset the clock, (page 9).
 If "call" shows on the display, call for service. (See "If you need service" below.)

See the Cooking Guide for more information on cooking problems and how to solve them.

2. If you need assistance* ...

**Call Whirlpool COOL-LINE[®] service assistance telephone number. Dial free from anywhere in the U.S.:
 1-800-253-1301**

and talk with one of our trained consultants. The consultant can instruct you in how to obtain satisfactory operation from your appliance or, if service is necessary, recommend a qualified service company in your area.

If you prefer, write to:

Mr. Donald Skinner
 Director of Consumer Relations
 Whirlpool Corporation
 2000 M-63
 Benton Harbor, MI 49022

Please include a daytime phone number in your correspondence.

3. If you need service* ...



Whirlpool has a nationwide network of authorized WhirlpoolSM

service companies. Whirlpool service technicians are trained to fulfill the product warranty and provide after-warranty service, anywhere in the United States. To locate the authorized Whirlpool service company in your area, call our COOL-LINE[®] service assistance telephone number (see Step 2) or look in your telephone directory Yellow Pages under:

APPLIANCES - HOUSEHOLD - ELECTRICAL APPLIANCES -
 MAJOR - SERVICE & REPAIR MAJOR - REPAIRING & PARTS

OR

WASHING MACHINES, DRYERS
 & IRONERS - SERVICING

WHIRLPOOL APPLIANCES
 AUTHORIZED WHIRLPOOL SERVICE

SERVICE COMPANIES
 XYZ SERVICE CO
 123 Maple ... 999-9999

4. If you need FSP[®] replacement parts* ...

FSP is a registered trademark of Whirlpool Corporation for quality parts. Look for this symbol of quality whenever you need a replacement part for your Whirlpool appliance. FSP replacement parts will fit right and work right, because they are made to the same exacting specifications used to build every new Whirlpool appliance.

To locate FSP replacement parts in your area, refer to Step 3 above or call the Whirlpool COOL-LINE service assistance number in Step 2.

5. If you are not satisfied with how the problem was solved* ...

- Contact the Major Appliance Consumer Action Panel (MACAP). MACAP is a group of independent consumer experts that voices consumer views at the highest levels of the major appliance industry.
- Contact MACAP only when the dealer, authorized servicer or Whirlpool have failed to resolve your problem.

Major Appliance Consumer
 Action Panel
 20 North Wacker Drive
 Chicago, IL 60606

- MACAP will in turn inform us of your action.

*When requesting assistance, please provide: model number, serial number, date of purchase, and a complete description of the problem. This information is needed in order to better respond to your request.

WHIRLPOOL[®] Range Product Warranty

GR001

LENGTH OF WARRANTY	WHIRLPOOL WILL PAY FOR
FULL ONE-YEAR WARRANTY From Date of Purchase	FSP* replacement parts and repair labor to correct defects in materials or workmanship. Service must be provided by an authorized Whirlpool SM service company.
WHIRLPOOL WILL NOT PAY FOR	
<p>A. Service calls to:</p> <ol style="list-style-type: none"> 1. Correct the installation of the range product. 2. Instruct you how to use the range product. 3. Replace house fuses or correct house wiring or plumbing. 4. Replace owner accessible light bulbs. <p>B. Repairs when range product is used in other than normal, single-family household use.</p> <p>C. Pick-up and delivery. This product is designed to be repaired in the home.</p> <p>D. Damage to range product caused by accident, misuse, fire, flood, acts of God or use of products not approved by Whirlpool.</p>	

WHIRLPOOL CORPORATION SHALL NOT BE LIABLE FOR INCIDENTAL OR CONSEQUENTIAL DAMAGES. Some states do not allow the exclusion or limitation of incidental or consequential damages so this limitation or exclusion may not apply to you. This warranty gives you specific legal rights, and you may also have other rights which vary from state to state.

Outside the United States, a different warranty may apply. For details, please contact your franchised Whirlpool distributor or military exchange.

If you need service, first see the "Service and Assistance" section of this book. After checking "Service and Assistance," additional help can be found by calling our COOL-LINE[®] service assistance telephone number, **1-800-253-1301**, from anywhere in the U.S.

® Registered Trademark/TM Trademark/SM Service Mark of Whirlpool Corporation